



SEPARATOR SYSTEM

Maintaining Process Efficiencies & Extending Product Life

Brentwood's all-new separator system can be installed directly into the tower basin or cooling loop to remove troublesome solids, dirt and debris. This prevents the accumulation of organics and sediment, which are the leading cause of early fill replacement, poor tower performance, and downstream equipment efficiency losses.



Reduce system energy and water consumption



Extend fill life by decreasing fouling potential



Lower maintenance costs and associated downtime



Improve efficiency of chemical treatment program

Backwash / Purge Water Consumption*

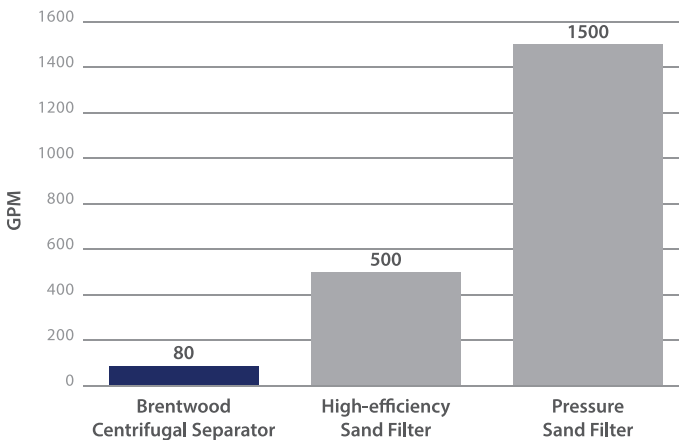

Filtration Capability**

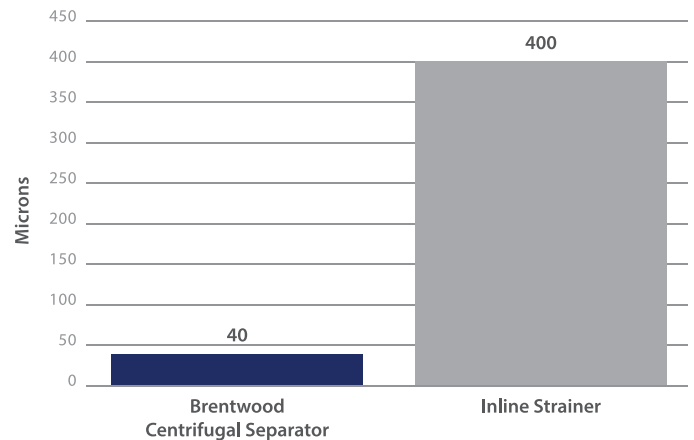

*Water consumption is a 24-hour aggregate, assuming continuous operation of a 1000-gallon filtration system.

**Filtration capabilities provided by centrifugal separator manufacturer.



Side Stream Application Sizing:

$$\text{Separator Flow (GPM)} = 0.10 \times \text{Main Recirculation Flow Rate (GPM)}$$

Select the model that delivers that exact or next highest flow.
Recommended sizing between 10-20% of main flow.

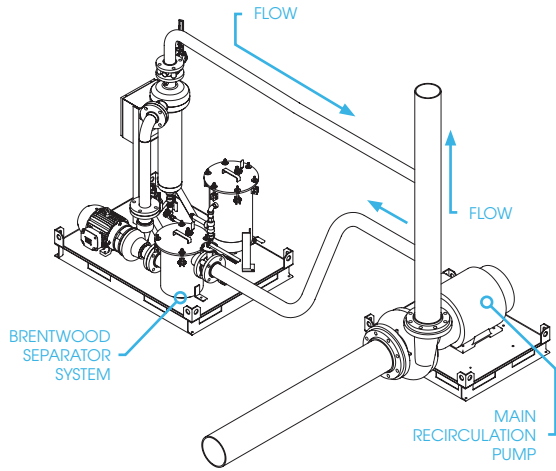

Basin Sweeping Application Sizing:

$$\text{Separator Flow (GPM)} = \text{Basin Length (ft)} \times \text{Basin Width (ft)}$$

Size by using 1 GPM per square ft. of tower basin area.
Select the model that delivers that exact or next highest flow.

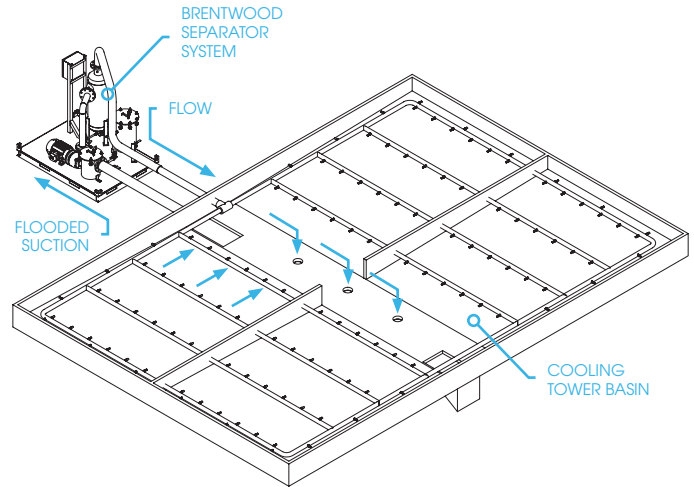

FEATURES

- Centrifugal separator efficiency of 98% for particles sized 40 microns with specific gravity of 1.8
- No filters or cartridges to replace
- Motorized purge kit automatically sends sediment to a drain for easy removal from the system
- Control panel for quick status determinations with available alarm outputs
- Isolation valves for system maintenance without having to shut down the cooling tower
- Strainer to separate large debris
- 80 TDH radial pump & totally enclosed fan-cooled motor
- Epoxy-coated separator and framework
- Can be used in crossflow or counterflow applications

SYSTEM SPECIFICATIONS

MODEL	FLOW (GPM)	INLET	DISCHARGE	HP	FOOTPRINT	APPROX.WEIGHT (LBS.)
BS-0040	40	2"	1"	2	36 1/2" x 28"	600
BS-0065	65	2"	1 1/4"	3	36 1/2" x 28"	620
BS-0100	100	2"	1 1/2"	3	36 1/2" x 28"	640
BS-0160	160	3"	2 1/2"	5	36 1/2" x 36 1/2"	800
BS-0220	220	3"	3"	7 1/2	36 1/2" x 28"	800
BS-0300	300	4"	3"	7 1/2	41" x 36 1/2"	900
BS-0450	450	4"	4"	15	40" x 40"	1150
BS-0600	600	5"	5"	20	42" x 42"	1400
BS-0850	850	6"	5"	20	49" x 48"	1950
BS-1200	1200	6"	6"	40	49" x 48"	2450

*Specified voltage is standard 460VAC/3Ph/60Hz. Non-standard voltage details available upon request.



+56 9 77968229

info@versval.com | www.versval.com

